

2

1

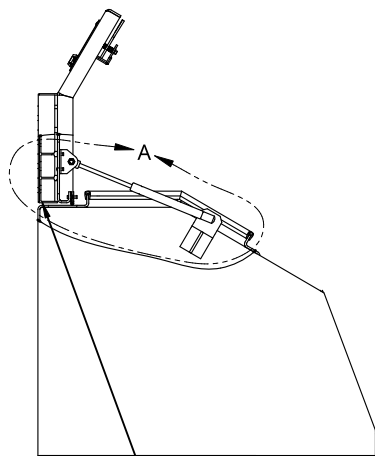

FLUSH WITH BACK OF
BOX WHEN OPEN TO
90 DEG

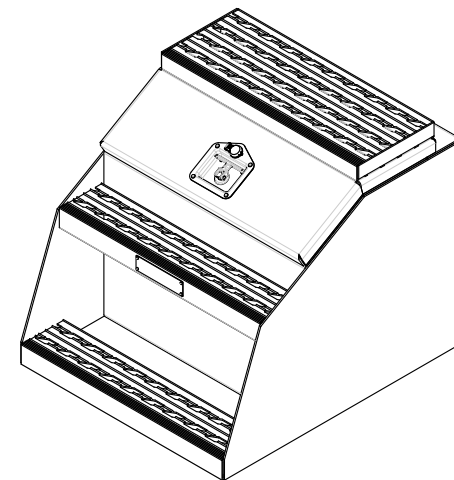
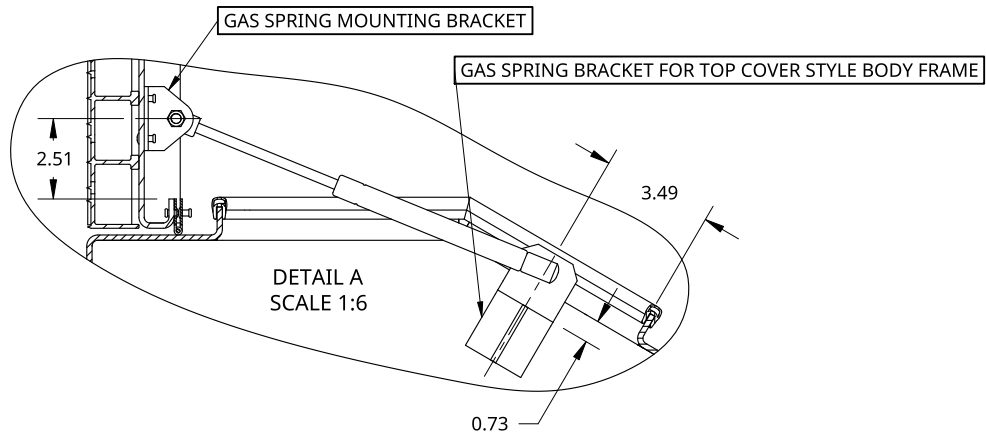
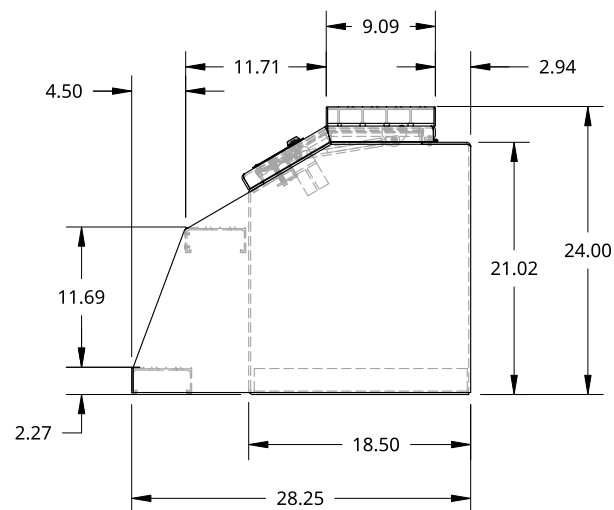
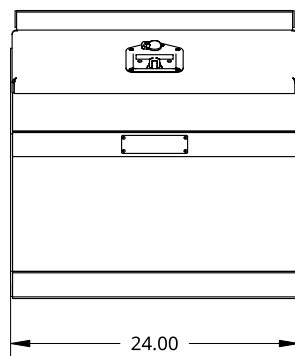

RELEASED

REVISIONS			
REVISION	REVISION DESCRIPTION	DATE APPROVED	APPROVER
A	RELEASED TO MFG	07/16/2021	SHAWN CROCKER
B	PART NUMBERED ALL PARTS AND CHANGE INNER REINFORCEMENT MATERIAL	11/17/2022	SHAWN CROCKER

THIS DOCUMENT IS THE PROPERTY OF TREBOR MANUFACTURING. ANY UNAUTHORIZED REPRODUCTION WILL BE PROSECUTED TO THE FULL EXTENT OF THE LAW

UNLESS OTHERWISE SPECIFIED, DIMENSIONS ARE IN INCHES

.XX = ±.1-
.XXX = ±.015-
.XXXX = ±.005-

ANGULAR = ±1°
FRACTIONAL = ±1/8

THIRD ANGLE PROJECTION

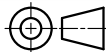

DRAWN BY SHAWN CROCKER 11/17/2022
CHANGED BY SHAWN CROCKER 11/17/2022

MATERIAL

1/8 ALU CHECKER

PART NO.		TRSTBBM24		REV.	B
BIG MOUTH STEP BOX - 28.25 X 24 X 24 - X1 T-HANDLE - 9IN TOP STEP					
SIZE	A	DWG NO.	D8029		REV.
SCALE	1:16	WEIGHT	55.07 LB	SHEET	1 of 1

2

1

B

B

A

A